

BETE[®]

NOZZLES FOR BOTTLE, DRUM, AND TANK WASHING

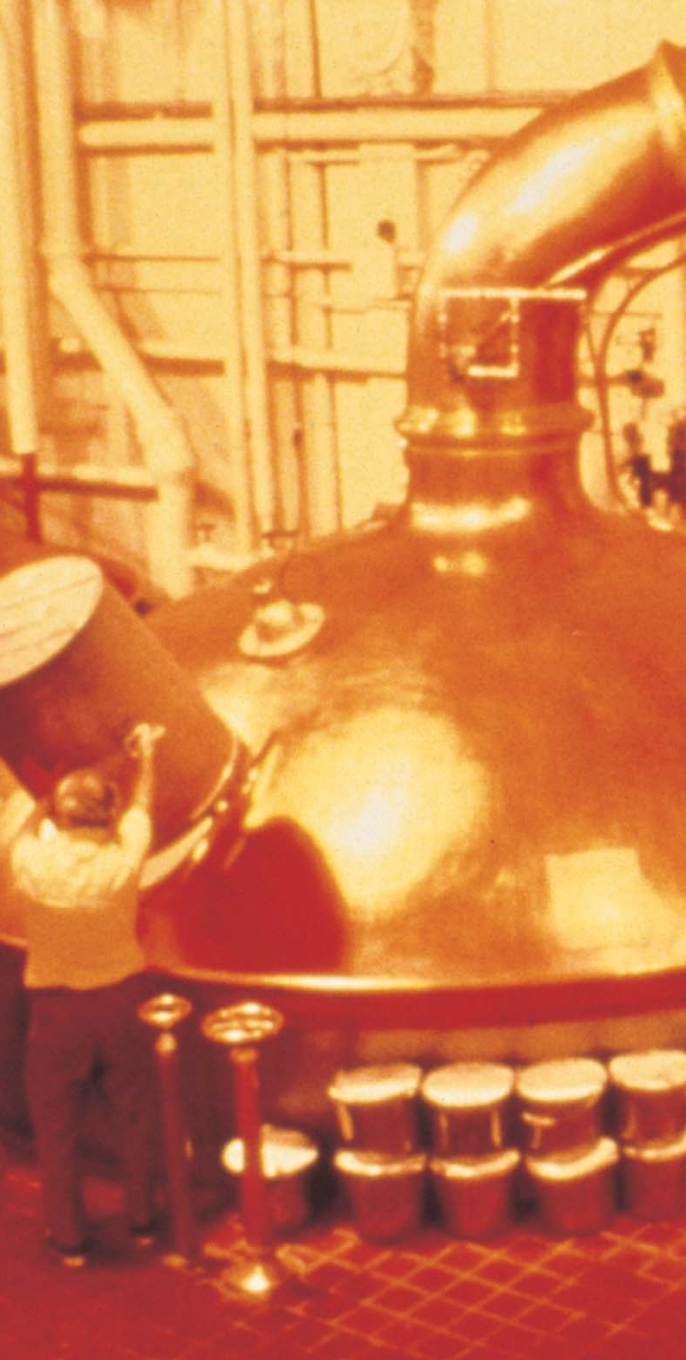

Manual No. 105.2TW



Choosing the Best Nozzles

Important Design Features to Consider When Choosing the Best Nozzle for Your Washing Needs

Adequate coverage and effective scrubbing are of prime importance in bottle, drum, and tank washing. Choosing from the variety of nozzles, both stationary and rotary can be confusing. In selecting BETE nozzles you should consider the following vessel characteristics and nozzle design criteria: size and shape of vessel to be cleaned; vessel opening; type of material to be removed; and spray coverage.

Size and Shape of Vessel to be Cleaned

BETE's tank washing nozzles can be used to clean, wash and rinse every size vessel from small bottles, moderately sized tanks, to railroad tankers (when used in multiples).

The TW series is the best choice for cleaning small bottles, kegs and barrels. Medium sized tanks up to 12' or 3.65m in diameter are best rinsed using the LEM or CLUMP series because of their omni-directional spray. Where higher impact is needed BETE's rotary nozzles, the RTWs and ScrubMates™, are excellent choices.

Vessel Opening

BETE's tank washing nozzles were designed to be inserted through narrower openings than any other competing designs.

If your vessel has a narrow opening or limited access port, the TW series has the smallest opening requirement. Next in line are the ScrubMate™ SM30 and RTW with small opening requirements. The LEMs and the CLUMPs require greater entrance diameters, up to 5.75" or 146mm.

Temperature Ratings for Materials

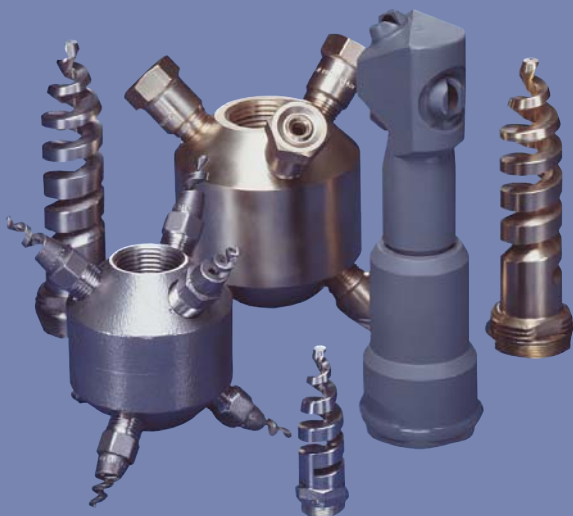
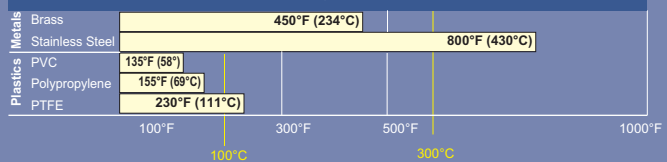

for Bottle, Drum and Tank Washing

Type of Material to be Removed

Another concern in choosing the correct nozzle should be the viscosity and the tenacity of the material to be removed within the vessel. Sticky viscous substances require greater scrubbing. This is most often accomplished with high impact sprays.* For high impact scrubbing a rotary nozzle, the RTW or ScrubMate™, will provide greater cleaning power if the vessel is not too large (see chart, on right). Less viscous material can be removed by washing and rinsing with lower impact, finer sprays. Liquids such as: fruit juices, beverages, pesticides, dyes, and fuels usually require less aggressive cleaning action. These can be rinsed extremely well using the BETE LEM, CLUMP, and TW series. Clog-resistant nozzles should be chosen when the nozzles are to be permanently mounted inside the vessels. The LEM, CLUMP and TW have large free passages to allow solids up to 0.13" (3.3mm), 0.19" (4.8mm) and 0.25" (6.4mm) in diameter, respectively, to pass without interfering with the cleaning process.

Temperatures should be considered when choosing nozzle materials. Some applications may be unsuitable for spray nozzles made from plastics (page 2).

Spray Coverage

Particular attention should be paid to spray coverage in selecting nozzles that are stationary or permanently mounted. The TW12 - TW20 and SM30-SM75 nozzles are particularly useful in cleaning processes where they are positioned to spray upward since they are designed to spray from the nozzle forward without emitting any backward spray. Short, wide tanks are best washed with omnidirectional LEMs and CLUMPs. TW1s are well suited to washing and rinsing taller drums, containers or tanks. BETE recommends nozzles be installed one-third down the inside of tanks having greater height than width for best rinsing effect.

Effective Scrubbing & Rinsing Distances at Various Pressures

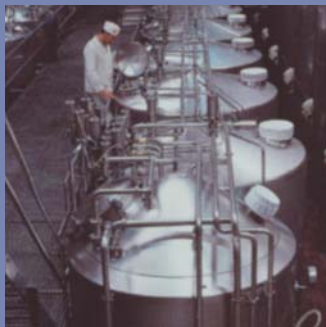
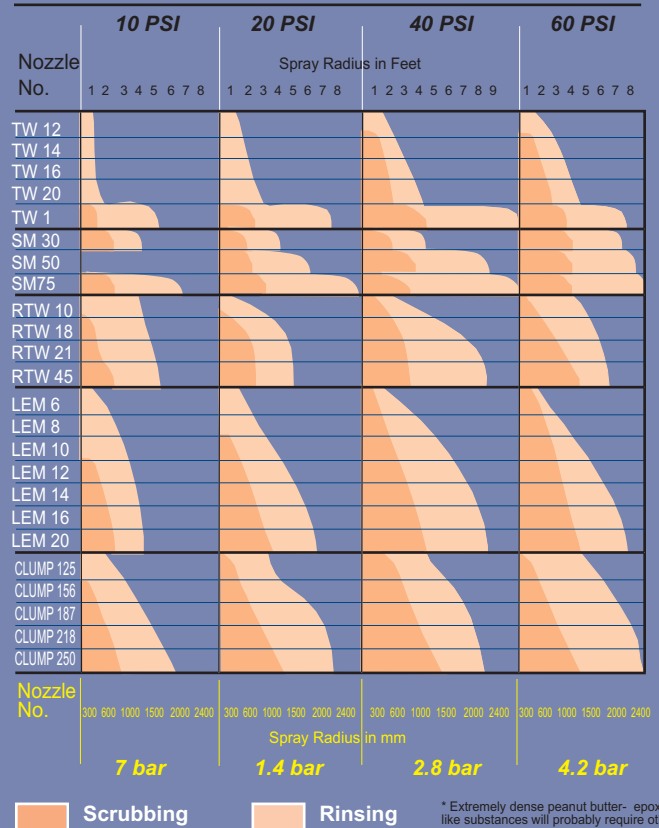

RTW & ScrubMate Mate

Rotary Tank Washing Nozzles



RTW series

- High impact spray evenly distributed over the entire vessel surface
- True tank washing and scrubbing
- Moderate diameter openings required (1.77", 45.0mm)
- Bearings can be cleaned/replaced without special tools

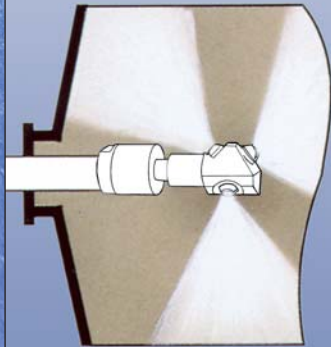

- Double bushings reduce wear, substantially eliminate leakage and give smoother operation (especially in horizontal position)

ScrubMate™ series

- High impact scrubbing action
- Compact feature fits through small openings. O.D.: **SM50**- 1.93" (49mm), **SM75**- 2.83" (72mm), **SM30**- 1.38" (35mm)

- Superior cleaning at low pressures
- No ball bearings
- Self-cleaning

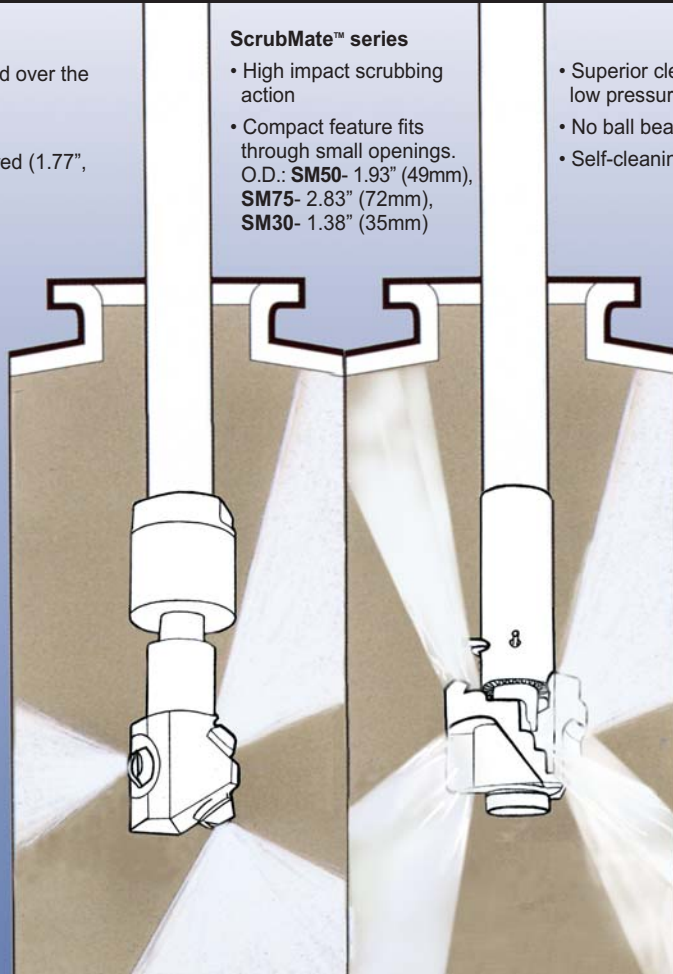

RTW

The RTW is a rotary tank washer consisting of a nozzle body fitted with three flat fan tips. The nozzles are self-powered with the angled fan tips providing rotational force.

The rotating flat fans produce high impact over the entire vessel surface. The RTW is the best choice for scrubbing moderately sized tanks (see chart, page 3). The housing design allows the bearings to be cleaned and/or replaced

easily. The design also accommodates a superior bushing system, eliminating leakage, reducing bearing wear, and allowing smoother operation in horizontal positions.

ScrubMate™

The ScrubMate™ series is a rotary tank washer specially designed for Clean In Place (CIP) tank cleaning applications in the wine, food, beverage, dairy, chemical and pharmaceutical industries.

The ScrubMate™ series has a self-powered rotating unique high impact head and a sanitary spring clip connector. This head creates large droplets providing a high degree of

washing impact. Its patented self-cleaning feature incorporates a downward wash-jet for cleaning centralized agitator units, and a cleaning stream that is also directed to the point of entry, top half and sides of tank for maximum cleaning efficiency.

LEM & TW

Stationary Tank Washing Nozzles

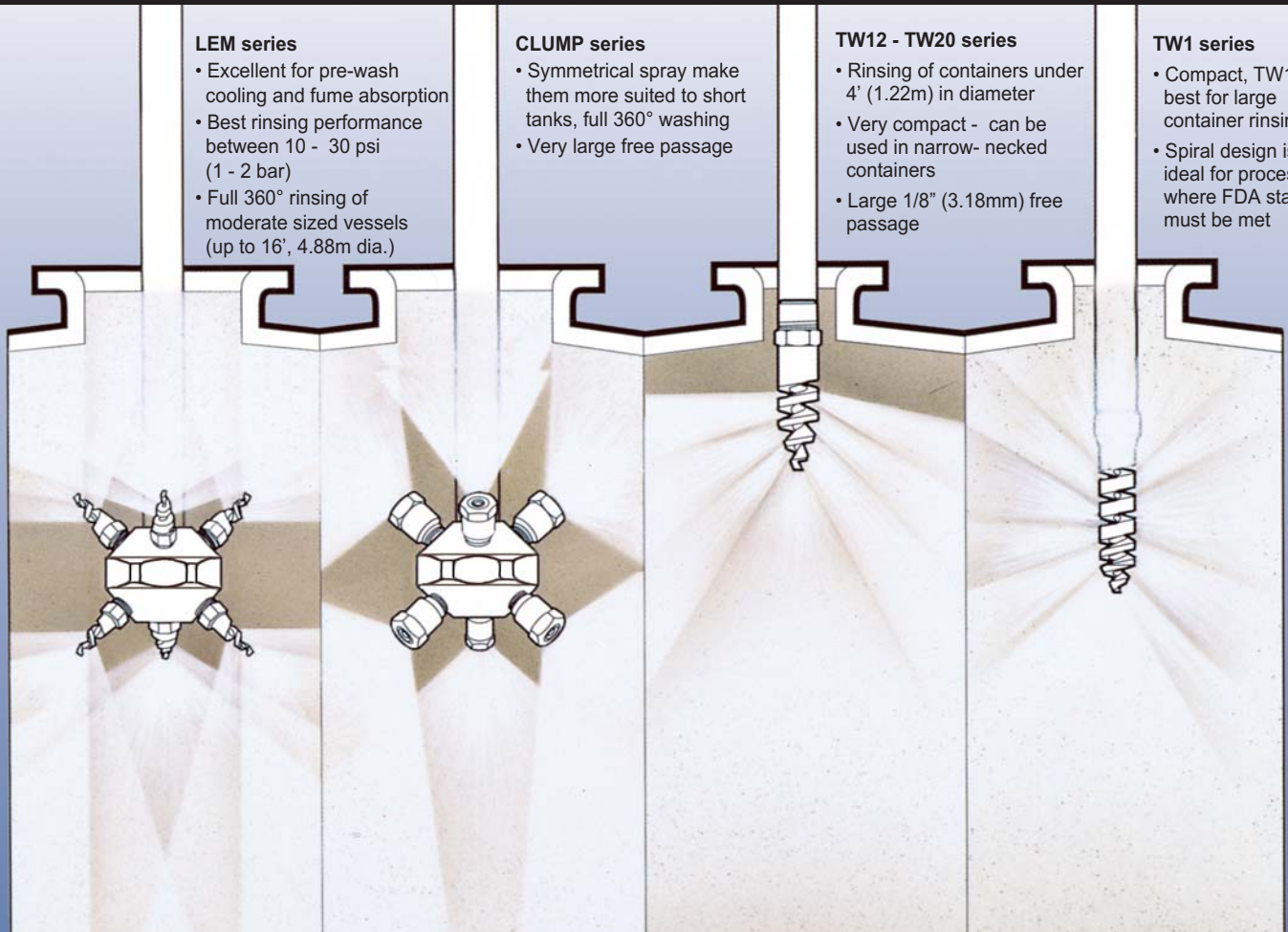

LEM series

- Excellent for pre-wash cooling and fume absorption
- Best rinsing performance between 10 - 30 psi (1 - 2 bar)
- Full 360° rinsing of moderate sized vessels (up to 16', 4.88m dia.)

CLUMP series

- Symmetrical spray make them more suited to short tanks, full 360° washing
- Very large free passage

TW12 - TW20 series

- Rinsing of containers under 4' (1.22m) in diameter
- Very compact - can be used in narrow-necked containers
- Large 1/8" (3.18mm) free passage

TW1 series

- Compact, TW1 best for large container rinsing
- Spiral design is ideal for processes where FDA standards must be met

LEM

The LEM series produces an omni-directional spray. The spray is relatively low impact, with individual spray cones producing good rinsing in targeted areas.

Typically the LEMs perform best at low to moderate pressures (10 - 30 psi, 1 - 2 bar, see chart, page 3.) This series, as well as the CLUMP series, creates symmetrical spray, "a wet puff-ball," and is best suited to tanks whose width exceeds their height.

CLUMP

The CLUMP is an assembly of MaxiPass™ nozzles in a manifold providing omni-directional coverage similar to the LEM.

The CLUMP provides an even spray pattern and a larger free passage. The CLUMP's peak performance is at 10 - 30 psi (1 - 2 bar). The CLUMP can fit through openings 4.75" and 5.75" (37.4mm and 146mm).

TW12 -TW20

The TW series is primarily designed to wash and rinse smaller containers such as kegs and barrels.

The TW12 - TW20 nozzles produce concentric spray cones of 180°, 120°, 90° and 50°. They are well suited to spraying upwards or horizontally. Like the LEM they perform best at moderate pressures (10 - 30 psi, 1 - 2 bar).

The TW spiral design has no internals and is a compact, clog-resistant, one-piece construction with no moving parts.

These physical design attributes make it ideal for food and pharmaceutical washing environments. The TW is an excellent choice for applications requiring FDA compliance.

TW1

The TW1 is of slightly different design, delivering backward spray at 90° and 120° angles and higher flow capacity. Tank rinsing rather than scrubbing is the most appropriate application.

HydroWhirl™ Orbitor tank cleaning machine is ideal for high impact cleaning

The HydroWhirl™ Orbitor is a versatile tank cleaning machine designed to meet the high standards required in the food, brewing, beverage, dairy, and chemical industries combining high performance cleaning efficiency with extended operating life and reduced life cycle costs.

Advantages of the HydroWhirl Orbitor tank cleaning machine.

- The HydroWhirl Orbitor can be stripped, maintained, and rebuilt in less than 15 minutes.
- The HydroWhirl Orbitor is self cleaning and self lubricated.
- Enhanced external cleaning with dedicated nozzles that clean the external surfaces of the machine and its mounting pipe.
- Designed for use where high impact cleaning is required.
- The HydroWhirl Orbitor is ideal for use in larger tanks and where the product is difficult to clean.
- Designed with minimum moving parts to ensure extended operating life and reduced down time.

Available Versions:

- 2 or 4 nozzle machines
- Variable cycle times
- Male or Female connections
- 360° wash pattern
- 180° down wash pattern
- 180° up wash pattern

Typical HydroWhirl Orbitor Applications:

Typically used where high impingement cleaning is required and where the most efficient use of utilities is necessary.

BREWING

Bright beer tanks, coppers, maltings

COATINGS AND PAINTS

Storage silos, process vessels, mixers

FOOD AND DAIRY

Raw milk storage, spray driers, process vessels, storage silos

CHEMICAL

Process vessels, mixers, storage silos

BEVERAGE

Process vessels, storage silos



Key Features and Benefits:

- Designed to meet hygienic standards
- Optimum consumption of water, chemicals, and time = reduced operating costs
- Minimum moving parts = reduced lifecycle costs
- Self cleaning; self lubricating = no process contamination
- High impact jets; orbital wash pattern = high efficiency cleaning process
- Compact design = will fit through small access flanges
- 2 or 4 nozzle configuration = wash pattern variable up to super intense
- External Surface Finish: 0.5 microns Ra or better

BETE Fog Nozzle, Inc. has been a pioneer in nozzle engineering, manufacturing, and applications for over 55 years. BETE nozzles are used throughout the food processing, chemical processing, and pharmaceutical industries. BETE Applications Engineering will work with you to help during trial runs and ensure you choose the optimal spraying solution.

BETE®

BETE Fog Nozzle, Inc.

50 Greenfield St.
Greenfield, MA 01301
T (413) 772-0846
F (413) 772-6729
www.bete.com

HydroWhirl™ Orbitor

High Impact Rotary Tank Cleaning Machine

DESIGN FEATURES

- Reduced operating costs
- Minimum moving parts = reduced life-cycle costs
- Self cleaning; self lubricating = no process contamination
- High-impact jets; orbital wash pattern = high efficiency cleaning process
- Compact design
- 2 or 4 nozzle configurations = wash pattern variable up to super intense
- Male or female connections

SPRAY CHARACTERISTICS

- 360 wash pattern
 - Variable cycle times
 - High impact cleaning
- Flow rates:** 21.5 - 160 gpm
Working Pressure: 45 - 145 psi

Materials:

Housing: 316L
 Nozzle Head: SAF 2205
 Gears: PEEK + 316 SS
 Bushings/Seals: Carbon Filled PTFE

Max. Working Temp.: 203°F (95°C)

Max. Ambient Temp.: 284°F (140°C)

Weight: 13.2 Lbs

Minimum opening size is 125 mm (5")
 for either a 2-nozzle or 4-nozzle
 standard-capacity model.

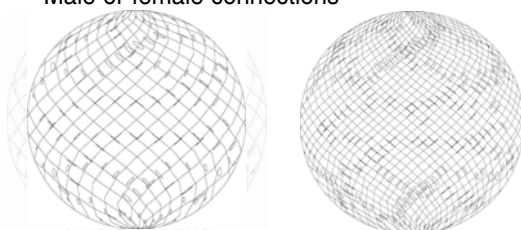

Orbitor 2 nozzle
spray pattern

Orbitor 4 nozzle
spray pattern

Jet lengths are effective cleaning lengths

Connection Size	4 X 4.2mm				4 x 5mm			4 x 6mm			4 x 7mm			4 x 8mm		
	1" and 1-1/2"				1" and 1-1/2"			1-1/2"			1-1/2"			1-1/2"		
Pressure (PSI)	Flow (gpm)	Jet Length (ft)	Cycle Time (min)	Flow (gpm)	Jet Length (ft)	Cycle Time (min)	Flow (gpm)	Jet Length (ft)	Cycle Time (min)	Flow (gpm)	Jet Length (ft)	Cycle Time (min)	Flow (gpm)	Jet Length (ft)	Cycle Time (min)	
45	22.6	9.5	11	31.4	13.1	13	38.6	17.4	15.5	59.1	21.3	20.1	68.3	23.6	15.5	
60	26.5	9.8	9.3	36.4	13.8	10.8	45.7	18.7	12.9	67.7	23.3	15.2	79.0	26.2	12.9	
75	30.0	11.5	7.9	40.8	15.4	9.4	52.1	20.3	11	75.2	25.3	14.9	88.4	29.5	11	
90	33.3	13.1	6.9	44.8	17.1	8	58.0	23.0	9.5	81.9	27.9	13	96.9	32.5	9.5	
100	35.3	16.4	6.3	47.2	20.7	7.3	61.8	26.2	8.4	86.0	30.8	11.7	102	34.8	8.5	
115	38.1	20.3	5.8	50.8	24.6	6.8	67.0	30.8	7.6	91.9	33.8	10.4	110	36.7	7.8	
130	40.8	23.3	5.6	54.0	27.9	6.5	72.1	33.8	7	97.3	36.7	9.3	117	40.0	7	
145	43.4	25.6	5.5	57.2	29.5	6.4	76.8	36.7	6.9	102	39.4	8.9	123	42.6	6.9	

Connection Size	2 x 6mm				2 x 7mm			2 x 8mm			*2 x 10mm			*2 x 12.5mm		
	1-1/2"				1-1/2"			1-1/2"			1-1/2"			1-1/2"		
Pressure (PSI)	Flow (gpm)	Jet Length (ft)	Cycle Time (min)	Flow (gpm)	Jet Length (ft)	Cycle Time (min)	Flow (gpm)	Jet Length (ft)	Cycle Time (min)	Flow (gpm)	Jet Length (ft)	Cycle Time (min)	Flow (gpm)	Jet Length (ft)	Cycle Time (min)	
45	21.5	18.0	33	26.1	21.3	37.5	33.5	23.6	25.7	59.1	32.1	41	89.4	33.1	26.8	
60	25.4	19.7	27.2	31.3	23.6	31.6	39.3	26.2	22.9	68.7	34.4	34.2	103	36.7	24	
75	28.8	20.7	24.7	36.0	25.9	28.2	44.4	29.5	20.5	77.2	37.7	30.5	115	39.7	21.7	
90	31.9	23.0	22.6	40.4	27.9	25.8	49.1	32.5	18.9	84.9	41.7	28	126	44.0	19.8	
100	33.9	26.2	21	43.2	9.2	24	52.0	34.8	17.5	89.8	45.6	26	133	48.5	18.4	
115	36.7	29.5	19.5	47.2	30.2	22.3	56.2	36.7	16.4	96.6	49.9	24.5	143	53.8	17.2	
130	39.4	33.5	18.4	51.1	37.0	21	60.1	40.0	15.6	103	55.8	23.2	152	60.0	16.3	
145	41.9	37.7	17.4	54.7	40.4	20	63.8	42.6	14.9	109	61.7	22	160	65.9	15.5	

*High Capacity Jet Machine

www.BETE.com

CALL 413-772-0846
 Call for the name of your nearest BETE representative.

HydroWhirl Poseidon™ spray nozzles for quick, efficient tank cleaning

The HydroWhirl Poseidon tank-washing nozzle directs the cleaning water through a rotating head at the tip of the spray assembly. This produces a slow-moving, high-impact spray action against internal surfaces of the tank. The HydroWhirl Poseidon nozzle head uses impact and repetition to quickly break up and wash away contamination. The combination of the spray pattern and slow rotation of the HydroWhirl Poseidon tank-washing nozzle is especially effective at removing scum rings or tougher, stuck-on material.

Advantages of the HydroWhirl® Poseidon™ rotary tank-washing nozzle:

- Cleans more quickly and uses less water and lower pressure than static tank washers
- Complete 360° omnidirectional coverage
- Slow rotation speed provides higher impact and more efficient cleaning.
- Durable PTFE nozzle construction withstands extreme chemical and elevated temperature environments.
- Simple internal design allows reliable flow-through operation
- Design validated by lab testing to 200°F (93°C)
- Maintenance-friendly design allows disassembly, inspection, and reassembly with basic hand tools.
- Made from FDA-approved materials for use in Clean-in-Place (CIP) applications

The HydroWhirl Poseidon tank-washing nozzle has been carefully designed for long service life

Comprehensive Quality Control:

- Material traceability controlled throughout production
- BETE product quality is maintained using a quality system registered to ISO 9001-2008

Design flexibility:

- Available with pipe, tube, or DIN clip-on connections. Threaded connections available upon request.
- Flow range: 15.3 to 89.5 gpm

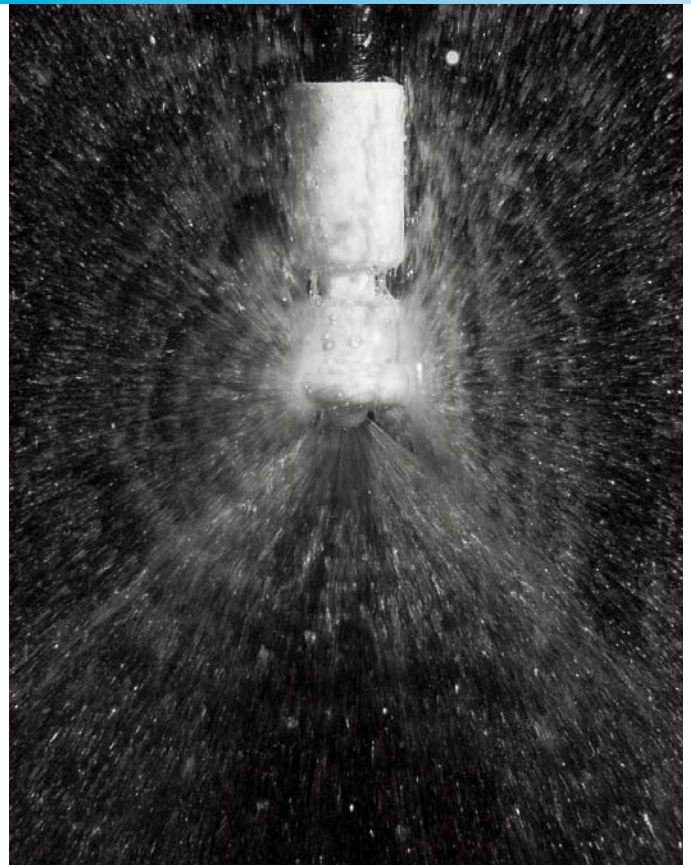

The HydroWhirl Poseidon tank-washing nozzle is an outstanding combination of design, quality, and performance. The HydroWhirl Poseidon tank-washing nozzle is ideal for anyone who needs a polymer nozzle for reliable, efficient cleaning of tanks and other interior spaces.

BETE Fog Nozzle, Inc. has been pioneering nozzles for the food-processing and pharmaceutical industries for over 60 years. Our Applications Engineering department will work with you to ensure you choose the right BETE nozzle for your application.

BETE®

BETE Fog Nozzle, Inc.

50 Greenfield St.
Greenfield, MA 01301
T (413) 772-0846
F (413) 772-6729
www.bete.com

HydroWhirl® Poseidon™

Tank Washing - PTFE Spray Nozzle

DESIGN FEATURES

- Cleans more quickly, and uses less water and lower pressure than static tank washers
- PTFE construction:
 - Ideal for harsh chemical environments
 - Corrosion resistant
- Three connections: pipe, tube, or DIN clip-on. Threaded connections available upon request.
- Made from FDA-approved materials for use in Clean-In-Place (CIP) applications.

SPRAY CHARACTERISTICS

- Slow spinning, longer spray dwell time on the target surface increases impact over conventional rotating designs
- Complete 360° omnidirectional spray pattern

Flow rates: 15.3 to 89.5 gpm

Minimum Tank Opening:

Small: 3", Large: 3.3"

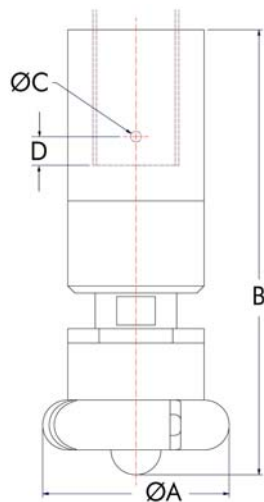

HydroWhirl Poseidon™ Nozzle Coverage Chart When spraying at 40 psi	
Nozzle Number	Washing Diameter (ft)
HWP-32	15
HWP-37	12
HWP-48	18
HWP-55	22
HWP-65	20
HWP-73	17

CONNECTION SIZES				
Connection Type	Body Size			
	SMALL		LARGE	
Pipe Clip On	3/4"	1"	1-1/4"	1-1/2"
Tube Clip On	1"	1-1/4"	1-1/2"	1-3/4"
DIN Clip On	20mm	25mm	40mm	

Threaded connections available upon request

Dimensions are approximate. Check with BETE for critical dimension applications.
Not recommended for applications over 60 psi.

HydroWhirl Poseidon™ Nozzle Flow Rates* and Dimensions

Body Size	Nozzle Number	Spray Angle	GALLONS PER MINUTE @PSI						Dimensions (in)				Wt (oz)
			10 psi	20 psi	30 psi	40 psi	50 psi	60 psi	A	B	C	D MAX	
SMALL	HWP-32	360°	15.3	22.2	27.6	32.2	36.3	40.0	2.94	6.40	0.19	0.50	21
	HWP-37		17.8	25.6	31.7	36.9	41.5	45.7					
LARGE	HWP-48		22.4	32.7	40.7	47.6	53.8	59.3	3.25	7.30	0.19	0.50	
	HWP-55		26.3	37.9	47.0	54.8	61.7	67.9					
	HWP-65		31.5	45.1	55.8	64.8	72.8	80.0					
	HWP-73		35.5	50.7	62.5	72.6	81.4	89.5					

Standard Materials: Nozzle: PTFE; Retaining Clip: 316 stainless steel

*Threaded connections may restrict the flow. Contact BETE for more information.

www.BETE.com

HydroWhirl® Poseidon™

Tank Washing - PTFE Spray Nozzle

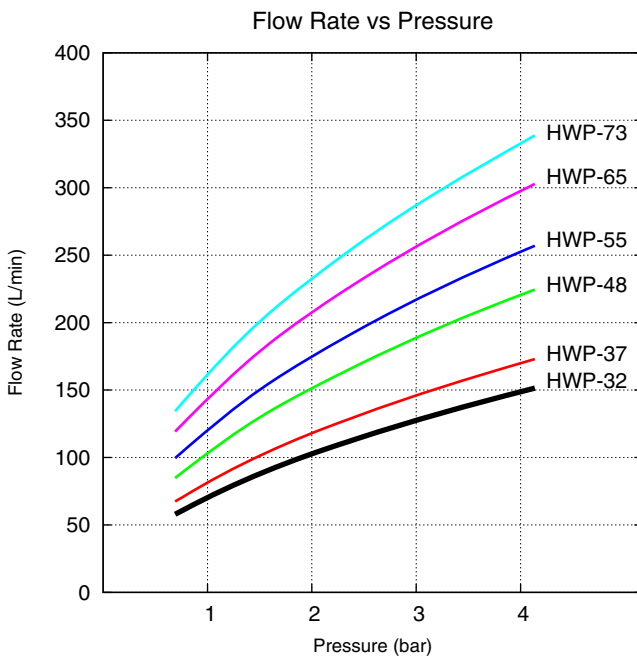
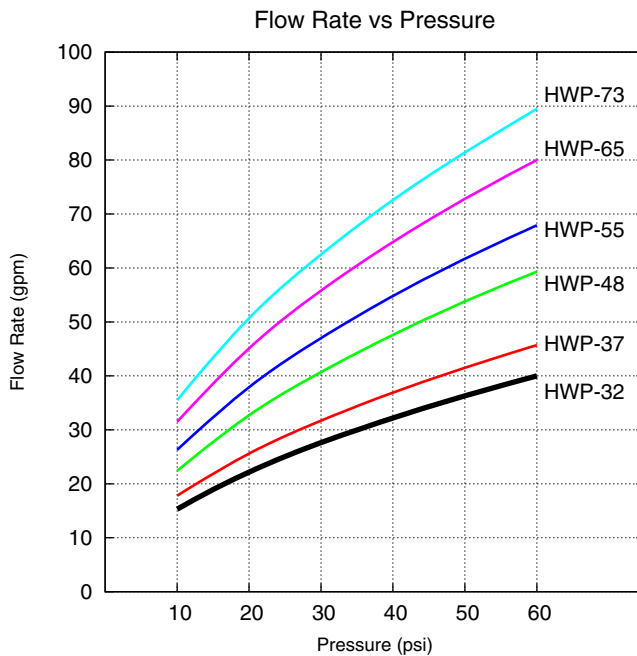

Threaded connections may restrict the flow. Contact BETE for more information.

CALL 413-772-0846
Call for the name of your nearest BETE representative.

HydroWhirl™ S slotted rotating spray nozzle for quick, efficient tank cleaning

The HydroWhirl™ S nozzle directs the cleaning water through a rotating head at the tip of the spray assembly. This produces a vigorous moving spray action against all areas of the walls of a tank. The spray pattern from the HydroWhirl S head uses impact and repetition to quickly wash the tank. This spray pattern is especially effective at breaking up and removing contaminants.

Advantages of the HydroWhirl S rotary spray nozzle.

- Cleans more quickly, but uses less water and lower pressure than static tank washers
- Complete 360° coverage
- Lower flow and pressure mean smaller pump size resulting in lower operating costs

The HydroWhirl S nozzle has been carefully designed for long service life.

Low-maintenance bearing design

- Self-cleaning bearings are lubricated by water flow to clear away particles

High-precision machining and finish

- Stainless steel construction – corrosion resistant
- Orbital welded design – durable assembly
- Made from rolled steel, not forged – no internal stress points
- Surface finish of 0.8 microns R_a or better
- 100% welded assembly
- Made to BETE quality standards by European high-precision stainless steel fabricator
- Made from FDA-approved materials for use in Clean-in-Place (CIP) applications

Comprehensive quality control

- Material traceability controlled throughout production
- Lab testing validates minimum service life of 300 hours



Surface finish ideal for sanitary applications

Design flexibility

- Available in many different sizes and connections – threaded, clip-on or welded
- 360° omni-directional spray pattern standard; other spray angles available upon request
- Flow range: 3.72 – 89.7 gpm
- Dual bearing design – nozzle operates effectively in any orientation

The HydroWhirl S nozzle is an outstanding combination of design, quality, and engineering. The HydroWhirl S nozzle is ideal for anyone who needs reliable, efficient cleaning of tanks and other interior spaces.

BETE Fog Nozzle, Inc. has been a pioneer in nozzle engineering, manufacturing, and applications for over 55 years. BETE nozzles are used throughout the food processing and pharmaceutical industries. BETE Applications Engineering will work with you to help during trial runs and ensure you choose the optimal spraying solution.

BETE®

BETE Fog Nozzle, Inc.

50 Greenfield St.
Greenfield, MA 01301
T (413) 772-0846
F (413) 772-6729
www.bete.com

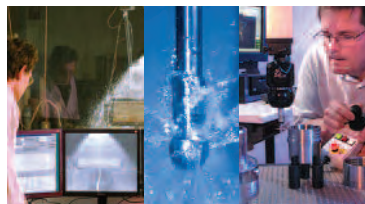

HydroWhirl™ S

Tank Washing - Slotted Spray Nozzle

DESIGN FEATURES

- Cleans more quickly, but uses less water and lower pressure than static tank washers
- Surface finish ideal for sanitary applications
- Orbital welded design - durable assembly
- Stainless steel construction - corrosion resistant
- Three connections - threaded, clip-on and welded
- Made from FDA approved materials for use in Clean-In-Place (CIP) applications.

SPRAY CHARACTERISTICS

- Self-cleaning bearings
- Vigorous moving spray action
- Complete 360° omnidirectional coverage

Flow rates: 3.72 to 89.7 gpm

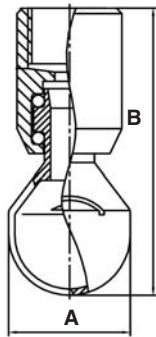
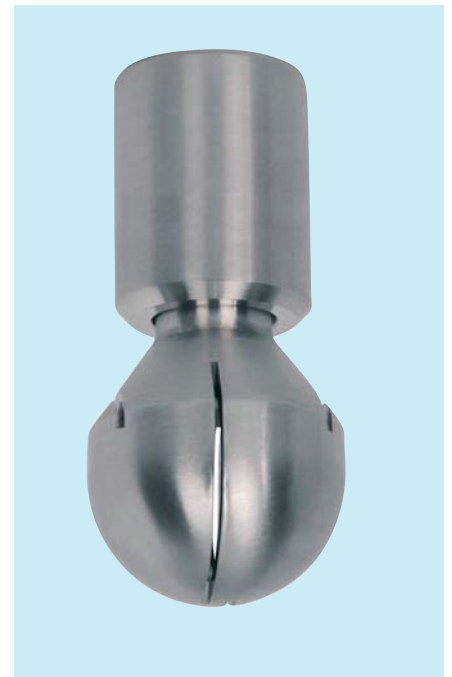

HWS-20 - HWS-50

HydroWhirl S Coverage Chart

When spraying at 40 psi

Nozzle Number	Washing Diameter (ft)
HWS-20	4.9
HWS-30	6.6
HWS-40	13.1
HWS-40 HF	13.1
HWS-50	19.7

CONNECTION SIZES

Connection Type	Nozzle Number				
	HWS20	HWS30	HWS40	HWS40HF	HWS50
Pipe Clip On	10 mm	3/8", 1/2"	3/4", 1"	3/4", 1"	1-1/2"
Tube Clip On	--	3/4"	1"	1"	2"
Pipe Weld On	1/4"	3/8", 1/2"	3/4", 1"	3/4", 1"	1-1/2", 2"
Tube Weld On	1/2"	3/4"	1"	1"	2"
FNPT	1/8"	1/4"	3/4"	3/4"	1-1/2"

Dimensions are approximate. Check with BETE for critical dimension applications.
Not recommended for applications over 60 psi.

HydroWhirl™ S Flow Rates and Dimensions

Female Pipe Size	Nozzle Number	Spray Angle	GALLONS PER MINUTE @PSI						Dimensions (in)		Wt (oz)
			10 psi	20 psi	30 psi	40 psi	50 psi	60 psi	A	B	
1/8"	HWS-20	360°	3.72	4.58	5.37	6.30	6.37	6.50	0.655	1.68	0.88
1/4"	HWS-30	360°	6.37	8.65	10.41	11.96	13.08	14.10	1.1	2.34	3.28
3/4"	HWS-40	360°	10.47	14.45	17.52	20.21	22.27	24.14	1.53	3.65	10.80
3/4"	HWS-40 HF	360°	16.66	23.09	28.05	32.39	35.74	38.80	1.53	3.65	10.64
1 1/2"	HWS-50	360°	37.96	52.96	64.26	73.60	82.08	89.70	2.72	6.1	53.76



LEM

Tank Washing Nozzle

DESIGN FEATURES

- Each nozzle in the stationary cluster is a BETE clog-resistant spiral nozzle of the TF Series
- Can be supplied with various other BETE nozzles for any desired application
- Female connection

SPRAY CHARACTERISTICS

- Spherical omni-directional coverage
 - Six nozzles arranged in cluster to project spray in all directions
- Flow rates:** 5.15 to 140 gpm
19.1 to 597 l/min
(special flow rates available, special tips upon request)

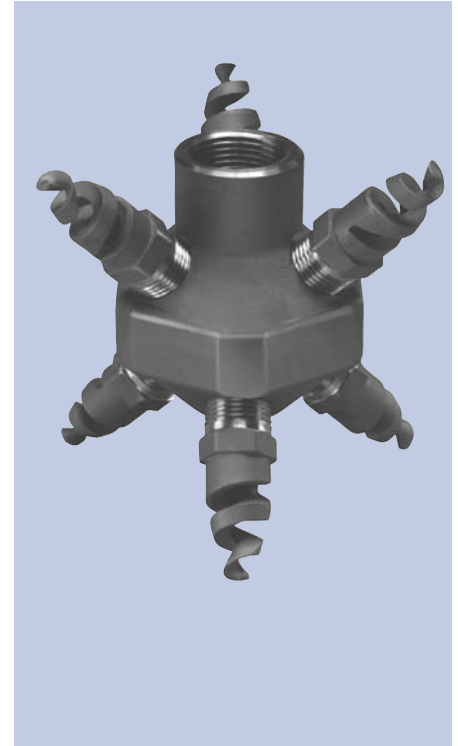

LEM Coverage Chart

When Spraying at 40 - 50 PSI, 3 - 4 BAR, BSP or NPT

Female Pipe Size	Nozzle Number	Scrubbing Dia. (ft.)	Rinsing Dia. (ft.)	Scrubbing Dia. (mm)	Rinsing Dia. (mm)
3/4	LEM6	1.5	3.0	450	900
	LEM8	3.0	6.0	900	1800
	LEM10	4.5	9.0	1400	2700
1	LEM12	6.5	13.0	2000	4000
	LEM14	6.8	13.5	2100	4200
	LEM16	7.2	14.5	2200	4400
	LEM20	8.0	16.0	2400	4900

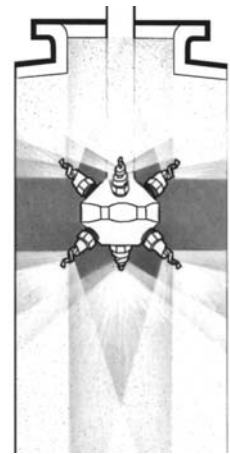
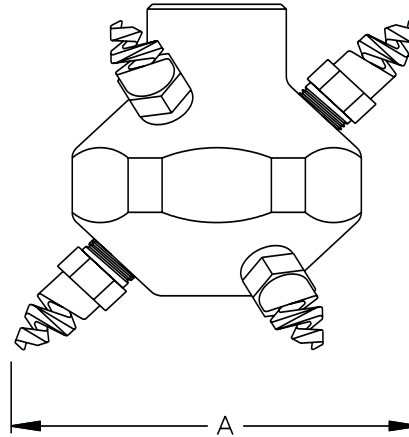

Typical LEM installation

LEM Flow Rates and Dimensions

Spherical, 360° Spray Angle, 3/4" and 1" Pipe Sizes, BSP or NPT

Female Pipe Size	Nozzle Number	K Factor	GALLONS PER MINUTE @ PSI					Minimum Entrance Open. (in.) A	Weight (lbs.) (oz.) Metal Plas.		K Factor	LITERS PER MINUTE @ BAR					Minimum Entrance Open. (mm) A	Weight (kgs.) (g.) Metal Plas.	
			15 PSI	30 PSI	40 PSI	60 PSI	80 PSI		1 bar	2 bar		3 bar	4 bar	5 bar	1 bar	2 bar			
3/4	LEM6	1.33	5.15	7.27	8.40	10.3	11.9	4.50	2.25	6.00	19.1	19.1	27.1	33.2	38.3	50.6	114	1.02	170
	LEM8	2.53	9.80	13.9	16.0	19.6	22.6					36.5	51.6	63.2	72.9	96.5			
	LEM10	3.95	15.3	21.7	25.0	30.6	35.4					57.0	80.6	98.7	114	151			
1	LEM12	5.69	22.0	31.2	36.0	44.1	50.9	5.25	4.13	11.0	82.0	82.0	116	142	164	217	133	1.87	312
	LEM14	7.68	29.7	42.1	48.6	59.5	68.7					111	157	192	222	293			
	LEM16	9.96	39.6	54.6	63.0	77.2	89.1					144	203	249	287	380			
	LEM20	15.7	60.8	85.7	99.0	121	140					226	319	391	451	597			

Flow Rate (GPM) = K √PSI

Flow Rate (l/min) = K √bar

Standard Materials: Brass, 316 Stainless Steel, PVC and PTFE.

TO ORDER: Specify pipe size, connection type, nozzle number, and material

CLUMP

Tank Washing Nozzles

DESIGN FEATURES

- Each nozzle in the stationary cluster is a BETE clog-resistant full cone nozzle of the MaxiPass™ series
- Can be supplied with various other BETE nozzles for any desired application
- Female connection

SPRAY CHARACTERISTICS

- Spherical omni-directional coverage
 - Six nozzles arranged in cluster to project spray in all directions
- Flow rates:** 7.52 to 68.1 gpm
28.6 to 254 l/min
(Special flow rates available)

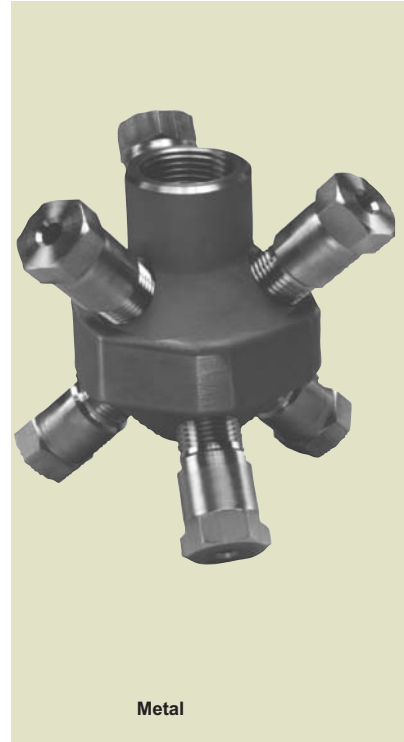

WHIRL

CLUMP Coverage Chart

When spraying at 40-50 PSI, 3 BAR, BSP or NPT

Female Pipe Size	Nozzle Number	Scrubbing Dia. (ft.)	Rinsing Dia. (ft.)	Scrubbing Dia. (mm)	Rinsing Dia. (mm)
3/4"	CLUMP125	4.0	8.0	1200	2400
	CLUMP156	4.0	12	1200	3700
	CLUMP187	6.0	14	1800	4300
1"	CLUMP187	6.0	14	1800	4300
	CLUMP218	8.0	14	2400	4300
	CLUMP250	10	16	3000	4900

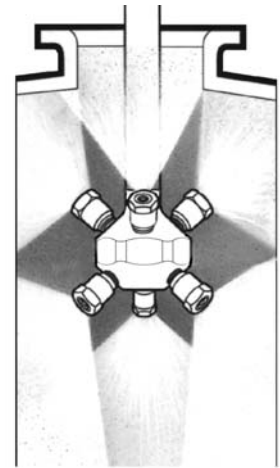
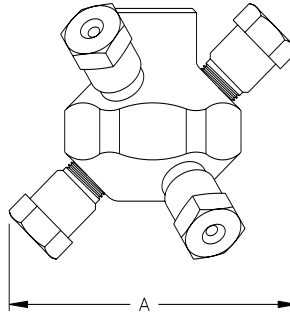

Typical CLUMP installation

CLUMP Flow Rates and Dimensions

Spherical, 360° Spray Angle, 3/4" and 1" Pipe Size, BSP or NPT

Female Pipe Size	Nozzle Number	K Factor	GALLONS PER MINUTE @ PSI					Minimum Entrance Opening (in.) A	Weight (oz.) Metal Plas.		LITERS PER MINUTE @ BAR					Minimum Entrance Opening (mm.) A	Weight (kg.) Metal Plas.		
			10 PSI	15 PSI	30 PSI	40 PSI	60 PSI		K Factor	0.7 bar	1 bar	2 bar	3 bar	4 bar					
3/4"	CLUMP125	2.73	7.52	8.99	12.2	13.8	16.5	4.75	2.85	8.0	33.5	28.6	33.5	45.5	54.3	61.7	120	1.29	0.22
	CLUMP156	4.34	11.9	14.3	19.4	22.0	26.3				53.2	45.5	53.2	72.2	86.3	98.0			
	CLUMP187	6.26	17.2	20.6	28.0	31.7	37.9				76.9	65.7	76.9	104	125	141			
1"	CLUMP187	6.26	17.2	20.6	28.0	31.7	37.9	5.75	5.16	14	76.9	65.7	76.9	104	125	141	146	2.34	0.40
	CLUMP218	9.96	27.4	32.8	44.5	50.5	60.3				122	104	122	166	198	225			
	CLUMP250	11.24	31.0	37.0	50.2	57.0	68.1				138	118	138	187	224	254			

$$\text{Flow Rate (GPM)} = K (\text{PSI})^{0.44}$$

$$\text{Flow Rate (l/min)} = K (\text{bar})^{0.44}$$

Standard Materials: 316 Stainless Steel.

Call for the name of your nearest BETE representative.

CALL 413-772-0846

TW

Tank Washing

DESIGN FEATURES

- Clog-resistant spiral design
- Energy efficient
- Compact design; fits small openings

SPRAY CHARACTERISTICS

- Easy to maintain
- Unique patterns that spray in opposing directions
- See LEM on page 25 for other tank-washing applications

Flow rates: 3.0 to 163 gpm

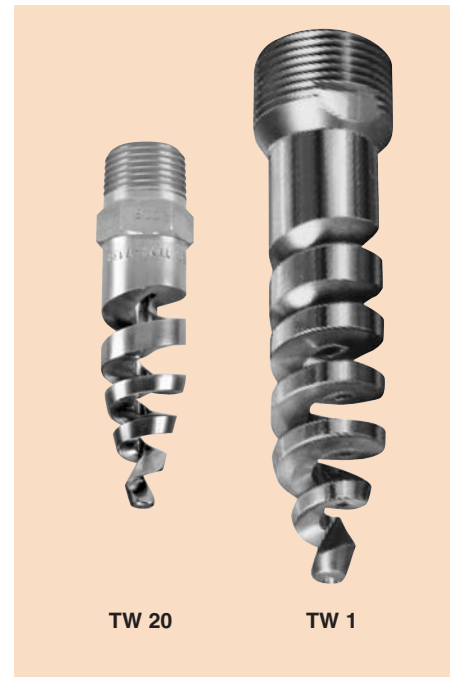

TW 20

TW 1

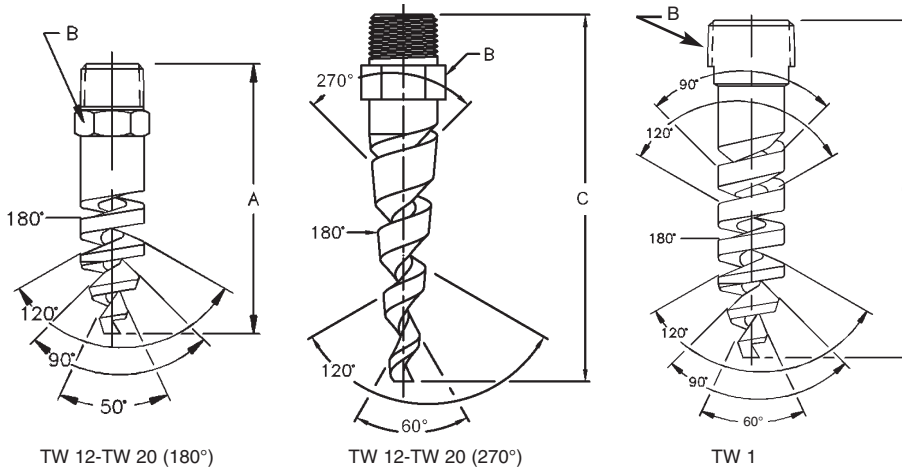

TW 12-TW 20 (180°)

TW 12-TW 20 (270°)

TW 1

Dimensions are approximate. Check with BETE for critical dimension applications.

Tank Washing TW Coverage Chart When spraying at 30-40 PSI

Pipe Size	Nozzle Number	Scrubbing Diameter (ft.)	Rinsing Diameter (ft.)
3/8	TW12	1.25	2.5
	TW14	1.5	4.0
	TW16	2.0	5.0
	TW20	3.0	7.0
1	TW1	8.0	20

Dimensions are approximate. Check with BETE for critical dimension applications.

Tank Washing Flow Rates and Dimensions TW 180° and 270°, 3/8" and 1" Pipe Sizes

Male Pipe Size	Nozzle Number	Available Spray Angle	K Factor	GALLONS PER MINUTE @ PSI												Approx. (in.)		Dimensions (in.)			Wt. (oz.)
				10 PSI	20 PSI	30 PSI	40 PSI	50 PSI	60 PSI	80 PSI	100 PSI	200 PSI	400 PSI	Orifice Dia.	Free Pass. Dia.	A	B	C			
3/8	TW12	180° 270°	0.949	3.00	4.24	5.20	6.00	6.71	7.35	8.49	9.49	13.4	19.0	0.19	0.13	2.88	0.75	3.63	1.75		
	TW14	180° 270°	1.28	4.05	5.73	7.01	8.10	9.06	9.92	11.5	12.8	18.1	25.6	0.22	0.13						
	TW16	180° 270°	1.68	5.30	7.50	9.18	10.6	11.9	13.0	15.0	16.8	23.7	33.5	0.25	0.13						
	TW20	180° 270°	2.61	8.25	11.7	14.3	16.5	18.4	20.2	23.3	26.1	36.9	52.2	0.31	0.13						
1	TW1	270°	8.06	26.0	36.0	45.0	51.0	57.0	63.0	72.0	80.6	115	163	0.56	0.20	1.13	5.75	10.5			

$$\text{Flow Rate (GPM)} = K \sqrt{\text{PSI}}$$

Standard Materials: Brass and 316 Stainless Steel.

Spray angle performance varies with pressure. Contact BETE for specific data on critical applications.

RTW

Rotating Tank and Drum Washing Nozzles

DESIGN FEATURES

- Fits through a 1.77", 45.0mm, opening
- Low leakage, resulting in water and chemical savings, and reduction in treatment costs
- Hardened 400 series Stainless Steel bearings.

SPRAY CHARACTERISTICS

- Slow rotation speed provides better cleaning
 - Wide coverage
- Flow rates:** 6.12 to 55.1 gpm
22.8 to 229 l/min

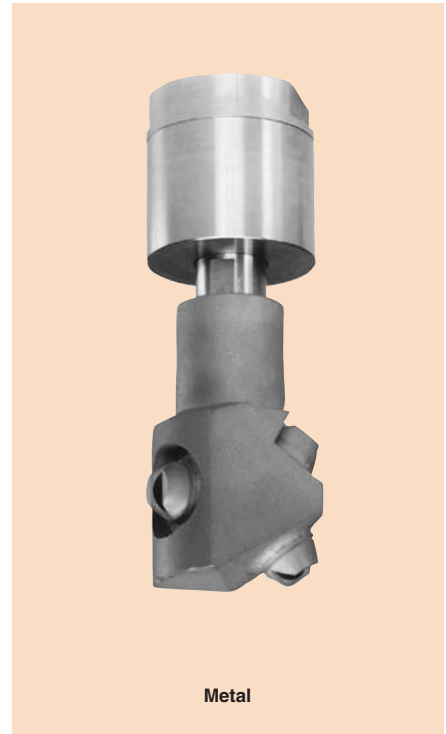

SPECIAL

RTW Coverage Chart

When spraying at 40 PSI, 3 BAR, BSP or NPT

Pipe Size	Nozzle Number	Scrubbing Diameter (ft.)	Rinsing Diameter (ft.)	Scrubbing Diameter (mm)	Rinsing Diameter (mm)
3/4"	RTW 10	2.0	6.0	600	1800
	RTW 18	4.0	8.0	1200	2400
	RTW 21	4.0	12.0	1200	3700
	RTW 45	6.0	14.0	1800	4300

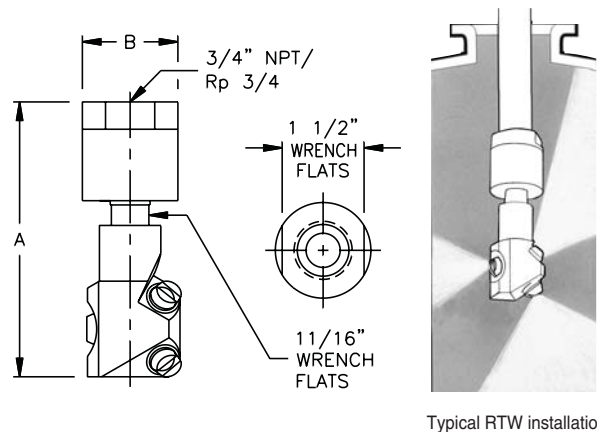

RTW Flow Rates and Dimensions

Wide Spray Angle, 3/4" Pipe Size, BSP or NPT

Female Pipe Size	Nozzle Number	K Factor	GALLONS PER MINUTE @ PSI					Equiv. Orifice Dia. (in.)	Approx. Dim. (in.) A B	Wt. (lbs.)	LITERS PER MINUTE @ BAR					Equiv. Orifice Dia. (mm)	Approx. Dim. (mm) A B	Wt. (kg.)			
			15 PSI	20 PSI	30 PSI	40 PSI	60 PSI				1 bar	2 bar	3 bar	4 bar	5 bar						
3/4"	RTW10	1.581	6.12	7.07	8.66	10.0	12.2	0.156	6.75	1.75	2.1	22.8	22.8	32.2	39.5	45.6	51.0	3.96	171	44.4	0.95
	RTW18	2.846	11.0	12.7	15.6	18.0	22.0	0.186				41.0	41.0	58.0	71.0	82.0	91.7	4.72			
	RTW21	3.320	12.9	14.8	18.2	21.0	25.7	0.203				47.9	47.9	67.7	82.9	95.7	107	5.16			
	RTW45	7.115	27.6	31.8	39.0	45.0	55.1	0.297				103	103	145	178	205	229	7.54			

$$\text{Flow Rate (GPM)} = K \sqrt{\text{PSI}}$$

$$\text{Flow Rate (l}_{\text{min}}) = K \sqrt{\text{bar}}$$

Standard Materials: 316 Stainless Steel.

TO ORDER: Specify pipe size, connection type, nozzle number, and material



BETE Fog Nozzle, Inc.
50 Greenfield Street
Greenfield, MA 01301 USA

Telephone: 413-772-0846 • 413-772-2166
FAX: 413-772-6729
e-mail: sales@bete.com
www.BETE.com

0908 2K